

**BOROUGH OF STRASBURG**

**RULES, REGULATIONS AND SPECIFICIATIONS**

**GOVERNING INSPECTION, REPAIR AND**

**REPLACEMENT OF CURBS AND SIDEWALKS**

Part 1 – Definitions and References

Part 2 – Inspection of Existing Curbs and Sidewalks

Part 3 – Products

Part 4 – Construction

Part 5 – Inspection / Acceptance

Part 6 – Standard Details

**DATE:**

**July 17, 2017**

PART 1 - DEFINITIONS AND REFERENCES

- A. Authority - These rules, regulations and specifications are promulgated in accordance with Section 104.5 of Ordinance No. 1990-2, as amended.
  
- B. Technical References
  - 1. ASTM - American Society for Testing Materials.
  - 2. PennDOT Publication 408 – Specifications
  - 3. PennDOT Publication 72M – Roadway Construction (RC) Standards
  - 4. PennDOT Publication 213 – Temporary traffic Control Guidelines
  - 5. All references shall be the edition current as of the date of issuance of the Borough permit.
  
- C. Description of Work
  - 1. This work consists of furnishing all equipment, labor, materials and performing all operations necessary to repair and/or construct curb and sidewalk, complete in accordance with Borough requirements.
  - 2. All new construction and repair work shall be performed by experienced and capable personnel. For other than standard vertical curb replacement, the Inspector may allow replacement in kind.
  - 3. Standard vertical curb is the only permitted curb for installation of new curbing in the Borough. Where approved by the Borough, a combination curb/sidewalk may be installed.
  - 4. A PennDOT Highway Occupancy Permit (HOP) shall be required for all work performed within the right-of-way of State Routes. All work in state roads shall conform to PennDOT regulations.
  
- D. Indemnification - Property owner and contractor shall indemnify Borough and its agents for all losses, claims, and legal proceedings arising from or associated with the construction/repair of the curb and/or sidewalk. Property owner shall comply with PennDOT insurance requirements for work within the right-of-way of along State Routes.
  
- E. Permit - A Permit must be obtained from the Borough or PennDOT, as applicable, prior to a repair and/or construction.
  
- F. Notifications
  - 1. The Borough shall be notified at (717) 687-7358.

- a. One (1) week prior to any removal of existing pavement and before any new construction takes place.
- b. After setting of forms, placement of stone bed and any required wire, and before placing of concrete.
  1. The property owner or his contractor shall contact the Borough for an inspection. The Borough shall be given a twenty-four (24) hour minimum prior notice to the on-site expected delivery of concrete.
- c. At time of delivery of concrete.
- d. After forms have been removed and before backfilling takes place.

G. General Requirements

1. The work area must be broom cleaned and neat at the end of each day.
2. Suitable barricades shall be placed around the work area in such a manner as to protect both pedestrian and vehicular traffic. Such barricades shall be continually maintained and properly lighted during night hours. Work zone shall be in compliance with PennDOT Publication 213, Temporary Traffic Control Guidelines.
3. Street excavation for curb installation shall be parallel to the finished curb not less than twelve inches (12") nor more than twenty-four inches (24") from the face of the curb and shall be saw cut in a straight line. All material excavated from the street shall be replaced with PennDOT 2A modified stone and compacted to within four inches (4") of the finished road surface. Borough shall be responsible for placement of the paving materials.
4. Where existing structures such as light standards, utility poles, fire hydrants and the like are within the limits of curb and sidewalk construction, an asphalt-impregnated fiber expansion joint, not less than one-half inch (1/2") in width, shall be placed completely around said obstruction for the full depth of the concrete (or brick). Expansion joint material shall be placed to form a square twelve inches (12") from each side of the obstruction. No obstruction shall be constructed within the limits of curb.
5. If, in the opinion of the Borough, downspouts must be placed within the sidewalk and curb, they shall traverse the sidewalk in four inch (4") SCH-40 polyvinyl chloride (PVC) pipe or such material approved by the Borough. A construction joint should be placed over the pipe.
  - a. One inch (1") reveal shall be maintained between the downspout invert and finished street surface.

- b. If insufficient grade/or cover exists for placement of downspouts within the sidewalk and curb, rain gutters within the sidewalks and curb are permitted by the Borough. Gutters shall be formed within the concrete of the sidewalk and curb and be not less than three and one-half inches (3 ½") nor exceed five inches (5") in width and not more than three-quarters inch (¾") deep.
  - c. Cover plate and channel trough in sidewalks may be used in replacement sidewalk. Existing cover plates may be reused if steel plate is in acceptable condition. Rusted, warped or damaged steel plates shall be replaced. Plates shall be held securely in place and the channel shall be half a four inch (4") PVC pipe.
6. Street signs shall be reset in the sidewalk in a four inch (4") thin wall polyvinyl chloride (PVC) sleeve. The pipe sleeve shall extend the entire depth of the concrete. In addition, the pipe sleeve shall be installed so that the edge of the sign being installed will be even with the sidewalk side (back) of the curb. No sign sleeves shall be installed within the limits of the curb. The bottom of the sign must be seven feet (7') above the sidewalk surface. The installation of signs shall not interfere with compliance with the United States Americans with Disabilities Act or regulations adopted pursuant thereto for clear area. Street sign installation shall also be in compliance with PennDOT Publication 111M, Signing Standards (TC-8700 Series).
7. Utility grade adjustment. All utility services such as, but not limited to, water boxes and sewer vents will be brought to grade of new sidewalk and lids shall be free of any concrete to allow easy access without chipping away concrete. Lids covered with plastic bags or equivalent, shall have coverings removed after the job is complete. Water boxes shall be adjusted by the Borough. All other utilities are the responsibility of the property owner.
8. All new and replacement sidewalks shall be a minimum of five feet (5') in width. Replacement sidewalk can be less than five feet (5') wide, but is at the sole discretion of the Borough.

## PART 2 - INSPECTION OF EXISTING CURBS AND SIDEWALKS

- A. The following are considered maximum allowable deficiencies. If a significant portion of the curb or sidewalk section (greater than 25%) fails to meet these standards, property owner will be required to make repairs or replace the affected curb or sidewalk section.
- B. Concrete Curb
  - 1. Materials - All curb shall be constructed of plain concrete. No other materials will be acceptable.
  - 2. Curb Face Reveal - The maximum reveal (face) is eight inches (8") for new vertical curb. The minimum reveal for existing curb is five and one-half inches (5 ½"). Existing curb with less

than a five and one-half inches (5 ½") reveal shall be replaced. A review of remedial measures by the Inspector will determine the replacement curb reveal dimension.

3. Leaning - Curbs that lean at an angle greater than fifteen degrees (15°) shall be replaced.
4. Profile - The profile of the curb shall be uniform. If the curb has settled, replacement will be required.
5. Cracks - Cracks of one inch (1") or less, but more than one fourth inch (1/4"), occurring at intervals greater than five feet (5') where there is no shifting of the curb, may be approved for filling with flexible crack sealant. Curb with multiple cracks within a five feet (5') length shall be replaced.
6. Horizontal or Vertical Offsets - Adjacent sections of curbing which have offsets of more than one-half inch (1/2"), either horizontally or vertically, shall be replaced.
7. Surface Damage - Spalling, chipping and/or crumbling that exceeds any of the dimensions shown shall be repaired. If the surface damage exceeds forty percent (40%) of the section area, the curb shall be replaced.
8. Curb/Sidewalks Offsets - Offsets between adjacent sections of curb and sidewalk shall not exceed one-half inch (1/2") either horizontally or vertically. Offsets of more than one-half inch (1/2") will require replacement of curb and/or sidewalk. If this occurs within a pedestrian travel path (i.e curb ramp), the offset shall not exceed one-fourth inch (1/4"). Offsets greater than one-fourth inch (1/4") in pedestrian travel path will require replacement of curb and/or sidewalk to conform to the United States Americans with Disabilities Act.
9. Repairs - Repairs may take the form of a new section, pargeting, or the use of approved epoxies and joint sealants, subject to the approval of the Inspector.
10. Curb replacement shall extend to the nearest joint in both directions.

#### C. Concrete Sidewalks

1. Minimum Width - Sidewalks less than thirty six inches (36") shall be replaced.
2. Uneven or Sunken Slabs - Any sidewalk slab or materials other than concrete or any portions of a brick sidewalk, that has settled greater than one inch (1") in twenty four inches (24") slope shall be replaced or repositioned.
3. Surface Continuity
  - a. Any crack, bump, heave, depression, separation, or other distortion of the continuity of the surface of the sidewalk shall not exceed one-fourth inch (1/4") in elevation

differential.

- b. Continuity of the surface of the sidewalk greater than one-fourth inch (1/4") in height and not more than one-half inch (1/2") maximum in height shall be beveled with a slope not steeper than 1:2.
  - c. Continuity of the surface of the sidewalk greater than one-half inch (1/2") in height shall be ramped.
  - d. Where the sidewalk abuts the curb, the elevation differential between the top of the curb and sidewalk surface shall not exceed one-half inch (1/2").
- 4. Surface Damage - Spalling, chipping and/or crumbling that exceeds any of the dimensions shown shall be repaired. If the surface damage exceeds forty percent (40%) of the panel area, the sidewalk shall be replaced.
  - 5. Repairs - Repairs may take the form of a new slab, pargeing, or the use of approved epoxies and joint sealants, subject to the approval of the Inspector.
  - 6. Sidewalk replacement shall be to nearest joints.

D. Other Sidewalks

- 1. Other Sidewalk - Sidewalks other than concrete shall be separately inspected and an individual determination made on a case by case basis to be consistent to the extent possible with the requirements for concrete sidewalks.
- 2. Curb and Sidewalk Combinations - The standards addressed herein for curbs and sidewalks shall apply to combination curb and sidewalks. Combination curb and sidewalks are not acceptable within the PennDOT right-of-way of State Routes.
- 3. Asphalt Paved Areas - Where paved asphalt areas abut the street (such as parking lots or services stations) a walkway may, at the discretion of the Inspector, be defined by painting two white lines each three inches (3") wide and a minimum of four feet (4') apart on the asphalt in the location where a concrete sidewalk would normally be installed. In areas within right-of-way of State Routes, the walkway shall be defined by two white lines each six inches (6") wide and a minimum of six feet (6') apart. This walkway area shall be kept clear of all obstructions.

E. Appeals

- 1. The Inspector makes initial inspection and determines needs for repair or replacement and reviews any other special circumstances that might warrant a variance from the standard requirements.

2. The Inspector determines whether a variance from standard specifications is appropriate to allow installation-repair-replacement with minimum disruption to existing trees, shrubs, porches or retaining walls.
3. The Inspector issues a notice to the property owner requiring the installation-repair-replacement of the curb and/or sidewalk. That notice will give a deadline for the property owner to file a written objection and request for modification of the notice.
4. If the property owner files a written objection and request for modification of the notice, and the property owner's written request is accepted by the Inspector, the Inspector will issue a second notice with the changes made. The property owner must then meet the completion deadline as established by the second notice.
5. If the Inspector does not agree with the property owner's request, the Inspector shall inform the property owner in writing, and the property owner has ten (10) days from the date of the Inspector's notification to request a hearing by Borough Council. The property owner may be required to provide drawings, photos, or other information to explain any special circumstances. Borough Council must schedule a hearing within thirty (30) days of receipt by the Borough of a written hearing request. Both the property owner and the Inspector have the right to present the testimony of expert and other witnesses.
6. After reviewing the request of the property owner and the results of the inspection, the decision of Council shall be final, subject to any further appeals allowed by law. If Council agrees to the property owner's request it will notify the Inspector to modify the notice. If Council does not agree to the property owner's request, the notice will stand. In either case, the property owner must meet the completion deadline as established by the Inspector's notice, unless a different date is established by Council.
7. Any variance from standard specifications will be valid only as long as the initial reason for the variance exists.
8. Any variance from requiring repairs will be valid until the condition of the curb and/or sidewalk, in the opinion of the Borough, worsens significantly, as defined within these specifications.

F. Standards for Variances

1. Variances shall only be granted by the Inspector or Borough Council, as the case may be, where there are unique physical circumstances or conditions, and the granting of a variance would not be detrimental to public safety. The burden of proof shall be upon the property owner. Subject to the foregoing, the following situations shall be relevant (but not conclusive) to requests for variances.

- a. Physical limitations on meeting standard specifications such as existing trees, fences, retaining walls, porches, buildings or lay of land.
- b. If a property abuts property that is undeveloped, or near a border of the Borough, sidewalks may not be required until further development occurs.
- c. Degree of repair or replacement requested.

### PART 3 - PRODUCTS

#### A. Materials

1. Concrete shall be air entrained structural concrete (Class A) having a minimum ultimate strength of three thousand three hundred (3,300) psi at twenty eight (28) days. A field slump test shall be performed in the presence of the Borough Inspector.
2. Accelerating Admixture for Concrete shall be calcium chloride meeting the requirements of ASTM D 98 and PennDOT Publication 408, Section 721.
3. Air-Entraining Admixture for Concrete shall meet the requirements for both AASHTO M154 and PennDOT Publication 408, Section 711.3(d).
4. Bituminous Paper shall be impregnated with asphalt or tar, meeting the requirements of PennDOT Publication 408, Section 727.
5. Coarse Aggregate shall be Type A meeting the requirements of PennDOT Publication 408, Section 703.
6. Concrete shall conform to specifications for Cement Concrete, as specified in PennDOT Publication 408, Section 704 for strength required.
7. Curing and Protecting Covers shall be white polyethylene sheeting with polyethylene fiber backing, white polyethylene sheeting with burlap backing, burlap, insulating mats, or foam insulation meeting the requirements of PennDOT Publication 408, Section 711.1.
8. Fine Aggregates shall meet the requirements of PennDOT Publication 408, Section 703.1.
9. Premolded Expansion Joint Filler shall meet the requirements of AASHTO M153 for Cork or Preformed Rubber Type, and ASTM D1751 for Fibre Type. Fabrication of the joint filler shall meet the requirements of PennDOT Publication 408, Section 705.1.
10. Reinforcement shall be billet-steel deformed bars, grade 60, ASTM A615 and PennDOT Publication 408, Section 709.

11. Retarding Admixture for Concrete shall meet the requirements of both AASHTO M194 and PennDOT Publication 408, Section 711.3.
12. Welded Wire Fabric shall meet the requirements of ASTM-A185, and PennDOT Publication 408 Section 709.3.

B. Concrete Mix

1. All materials shall conform to PENNDOT Publication 408. The use of calcium chloride will not be permitted in concrete used in repair or construction.

**CONCRETE REQUIREMENTS**

ITEM	MINIMUM	MAXIMUM
Comprehensive Strength (28 Days)	3,300	
Air Entrainment	4%	6%
Slump (Regular Forming)	1.5"	3"
Slump (Slip Forming) *		1.5"

\*Note: High-strength early setting concrete is to be used when slip forming.

C. Submittals

1. Material Certification - If requested by the Borough, material certificates signed by material producer and contractor, certifying that each material item complies with, or exceeds, specific requirements shall be provided to the Borough Inspector.

**PART 4 - CONSTRUCTION**

A. General Requirements

1. Schedule - Concrete for curbs, sidewalks and/or driveway aprons may be placed between April 1 and October 31 of each calendar year. Exceptions to this schedule may be permitted upon request to and approval by the Borough. Concrete placement and protection shall be in accordance with PENNDOT Publication 408.
2. Responsibility for Cost - The property owner will be responsible for the cost of construction, reconstruction, replacement or repairs. In addition, the property owner will be responsible for the restoration of any disturbed areas including landscaping, trees, and other plantings without reimbursement.
3. Transition Pieces - Transition pieces may be used to bridge any mismatch in alignment between new and existing sidewalks that are adjacent. All transition pieces shall be approved by the Inspector.

a. General

1. Transition pieces are used to bridge any differential in either vertical and/or horizontal alignment between new and existing curbs and/or sidewalks that are immediately adjacent.
  2. All transition pieces and replacement of existing transition pieces shall be approved by the Inspector.
  3. Transition sections for both curbs and sidewalks shall have a maximum slope of one inch (1") in twenty four inches (24").
  4. If a property owner desires or is required to install new sidewalk and/or curb and a transition piece will be needed, the Borough shall contact the adjoining property owner (i.e. the owner of the property which needs the transition piece), and request that the adjoining property owner coordinate the installation of the transition piece with his or her neighbor (i.e. the owner of the property installing the new sidewalk and/or curb and negotiate an equitable cost sharing arrangement). If the two property owners are unable to mutually agree upon the installation of the transition piece, the Borough may, after prior notice to the adjoining property owner and after affording the adjoining property owner and opportunity to install the transition piece, cause such work to be done and collect the cost thereof together with all addition charges and expenses from the adjoining property owner. Nothing contained in these regulations shall be interpreted to imply a waiver to the Borough's right to require the adjoining property owner's compliance with these regulations or to require the adjoining property owner to construct, replace and repair sidewalks.
4. Grass Strips - Grass strips between curbs and sidewalks will be allowed in accordance with the standards included elsewhere in these Rules, Regulations and Specifications. Where grass strips are requested by the property owner for existing streets, the Borough will establish the width, if any.
- a. Whenever possible, property owners shall maintain a uniform design for curb and sidewalk replacement. If a grass strip exists between the curb and sidewalk, the grass strip shall be preserved when sidewalk is replaced, particularly when the majority of sidewalks within a block contain grass strips. If a sidewalk without a grass strip is replaced and a majority of the sidewalk within the block have a grass strip, a grass strip shall be provided.
  - b. Planting of trees in the grass strip area shall be in accordance with approved species as listed and provided at the Borough office.
  - c. Root barrier material shall be installed in accordance with manufacturer's specifications to prevent tree roots from heaving sidewalk and curb.

- d. Planting of shrubs and hedges shall be prohibited.
  - e. Placement of non-plant matter shall be approved by Borough.
5. Sidewalk Rear Lines - The rear lines of sidewalk shall be continuous to the extent possible. Where rear lines cannot be continuous, transition pieces will be required.
  6. Sidewalks shall have a uniform fall of one-fourth inch (1/4") per foot from the rear edge of sidewalk toward the curb. The grass strip between the sidewalk and curb shall conform to the same slope.
  7. Tree Planting - Curbside tree plantings will not be discouraged, even though tree plants behind the sidewalks are preferred. Discretionary variances may be granted by Borough Council to protect existing trees. Repair of curb and sidewalk damage caused by trees will be the responsibility of the property owner. A list of recommended trees is available from the Borough.
    - a. Planting of specific tree species shall be permitted within the sidewalks without grass strip areas only if provisions are made for adequate tree opening. This shall be at least two feet (2') by four feet (4') in dimension.
    - b. Root barrier material shall be installed in accordance with manufacturer's specifications to prevent tree roots from heaving sidewalk and curb.
    - c. Sidewalk clearance to the rear of the tree opening shall comply with the United States Americans with Disabilities Act and all regulations adopted pursuant thereto.
  8. Warning and Protective Devices/Liability - It shall be the duty of every property owner grading, constructing, draining, paving or repaving the sidewalk abutting his property, to provide and maintain adequate guards, barriers and lights to prevent accidents and such owner shall assume all risks and liability for all damages by reasons of such work, and by reasons of any failure to properly fill such area. Property owner and contractor shall indemnify the Borough and its agents for all construction related claims.
  9. Alternate Passage Around Obstruction/Water Courses - Whenever any obstruction is made by either excavation or otherwise, under or across any part of any footway or sidewalk for any purpose whatever, a safe and convenient passage shall be provided around or over the same for public travel, the watercourses shall be kept open for the free passage of surface waters.
  10. Failure to Complete - If a property owner fails to complete the necessary work within the time period stated in the notice/permit, the Borough may order the work to be done under a

municipal lien for the cost thereof and ten (10%) percent additional, together with interest, court costs and attorneys' fees as allowed by the law.

11. Specifications - Prior to the commencement of construction, reconstruction or repair, the detailed specifications, in effect at the time, shall be obtained from the Borough.
12. Permits - Permits will be required prior to commencing all curb and sidewalk work. All construction, replacement and repair work will be inspected by the Borough.

B. Grade Sheets

1. Except where the property is located between two acceptable curb lines, or at the discretion of the Inspector, the Borough will furnish grade sheets for the finished grade of the curb unless otherwise indicated. Borough will not provide grade sheets for work covered by a land development plan.
2. Reference hubs, or nails shall be protected and preserved by the Contractor for reference and checking. The Contractor shall be responsible for resetting any hubs or nails disturbed or lost.
3. The property owner will be responsible for the cost of grade sheets furnished, if not used within two (2) years.

C. Monuments

1. No monument or property corners shall be covered or disturbed by the construction of permanent sidewalk or curb.
2. Whenever monuments are either above or below the finished grade of a sidewalk, the Borough shall be given sufficient notice to permit resetting of the monument prior to pouring of concrete. Borough has sole discretion as to the resetting of the monuments.

D. Excavation

1. Excavation shall be made to the required depth, and the material upon which the curb and/or sidewalk is to be constructed shall be compacted to a firm, even surface.
2. Curb - Excavation shall be made to the required depth and the material upon which the curb is to be constructed shall be compacted to ninety-five percent (95%) of Standard Proctor Density of material. A layer of crushed stone (2B) not less than four inches (4") thick shall be placed under the curb.
3. Sidewalk - Excavation shall be made to the required depth, and layer of crushed stone (2B) not less than four inches (4") thick shall be placed and compacted to ninety-five percent (95%)

of Standard Proctor Density of material prior to the laying of sidewalk. All topsoil and all other vegetation shall be removed prior to placement of four inches (4") of crushed stone (2B).

## E. Curbs

### 1. Forms

- a. Forms for the curb shall be of metal, except wood forms may be used on sharp curves and short tangent sections when approved by the Borough. Forms shall be straight, free from warp and of sufficient strength when staked to resist the pressure of the concrete without springing. At least three (3) stakes shall be provided for each ten feet (10') of form. Metal forms shall be an approved section and shall have flat surface on top, and wood forms shall be nominal two inch (2") surfaced planks surfaced on the inside and top. These forms shall be of a depth equal to the depth of the curb, designed to permit secure fastening of the face and back forms at the tops. These fastenings shall be constructed in a manner that will not obstruct satisfactory finishing and edging of the top of the curb, and will permit removal of the inside or face forms. The outside or back forms shall be straight from top to bottom. The inside of the face forms shall have a batter from the top of the curb to the finished surface line of the pavement, as indicated on the Standard Drawings, and shall be straight from this line to the bottom. A front and back form shall be used for curbs except where good concrete sidewalk, which is not be removed, abuts the new curb.
- b. All forms and templates shall be thoroughly cleaned and treated with form oil, as required to prevent the concrete from adhering thereto. Other commonly available materials such as oil, motor oil, bituminous paper or other materials which will adhere to or discolor the concrete shall not be used.
- c. Forms that are worn, bent or damaged shall not be used.
- d. The forms shall be accurately set to line and grade in a manner to prevent settlement or displacement.

### 2. Placing and Finishing Concrete

- a. The concrete shall be placed in the forms in horizontal layers not to exceed five inches (5") and spaced sufficiently to eliminate all voids. An approved vibrator may be used when permitted by the Borough. Where indicated or directed, drainage openings shall be made through the curb to the elevation and size required.
- b. Curb shall be depressed, as indicated or directed. The top surface of the curb shall be finished true to line and grade in a smooth, neat and even manner by means of wood floats and the edges of the face and back shall be rounded to a radius of not

more than three-fourth of an inch (3/4") and one fourth of an inch (1/4"), respectively while the concrete is still plastic.

- c. Curbs to be installed shall be constructed of concrete with a seven inch (7") dressed surface on top, an eight inch (8") exposed face or reveal along the street side, which shall likewise be depressed and extended a minimum of ten inches (10") below street surface and have an eight inch (8") base. The exposed surface or reveal on the street side shall include a one inch (1") batter from the street surface to the top of curb.

- 1. Portions of curb, which are replaced between two satisfactory reveal sections, shall have the same exposed surface or reveal as the exiting curb.

### 3. Curb Machine

- a. Plain cement concrete curb may be placed with a self-propelled machine consisting of a hopper, power-driven screw or screws and a metering device. The concrete shall be designed with a slump of one and one half inch (1 1/2") maximum.
- b. Concrete shall be uniformly fed to the machine and after extrusions, the concrete shall maintain the shape of the section without slumping. The finished curb shall have a surface free from voids and honeycomb. Any additional surface finishing required shall be performed immediately after extrusion.

### 4. Joints

- a. Contraction joints shall be spaced in uniform lengths or sections of fifteen feet (15') maximum, except where shorter sections are necessary for closures or curbs. No section shall be less than four feet (4').
- b. Contraction joints may be either hand-formed or sawed joints. They shall be three-sixteenth inches (3/16") wide and one and one-half inches (1 1/2") deep minimum. The contraction joint shall traverse the top and continue down the face of the curb at a minimum of ten inches (10") on the street side. Expansion joint material may be substituted for contraction joints. Sawing of joints shall be done as soon as practicable after the concrete has set sufficiently to preclude raveling during the sawing and before any shrinkage cracking occurs in the concrete.
- c. Construction/expansion joints shall be placed every sixty feet (60') with one-half (1/2") premolded asphalt impregnated fiber expansion joint material and tooled edges. The one-half inch (1/2") premolded asphalt impregnated fiber expansion joint material shall be cut to conform to the cross sectional area and be placed at structures, at the end of a day's work, at the beginning and end of radius, and at the change in horizontal alignment or property line.

5. Handicap Access - New or replacement curb shall be depressed, as noted on any approved plans, Standard Drawings, or as directed by the Borough, to accommodate access to sidewalks by the handicapped. The curb depression shall be flush with the adjacent roadway surface. All depressed curbs for handicap access shall comply with the United States Americans with Disabilities Act and all regulations adopted pursuant thereto.
6. Driveways
  - a. New or replacement curb shall be depressed across driveways with an exposure of one and one-half inches (1 ½"). Two (2) No. 4 steel deformed, reinforcing bars shall be placed two and one-half inches (2 ½") below the finished depressed curb surface. The steel bars shall continue a minimum of two feet (2') on either side of the driveway depression.
  - b. A contraction joint shall be placed or saw cut at the transition point from full reveal curb to depressed curb on either side of driveway depression.
  - c. Concrete sidewalk will be required across the driveway and a concrete driveway apron shall be provided, as indicated on the Standard Drawings. Sidewalks across driveways shall be constructed without any step or break from abutting sidewalk or, at a minimum, shall conform to the requirements of the United States Americans with Disabilities Act and the regulations adopted pursuant thereto.
  - d. Where curb returns occur at driveways, curb ramps shall be constructed on each side of the driveway.
7. Removal of Forms
  - a. The forms shall not be moved within twenty-four (24) hours after the concrete had been placed and minor defects shall be filled with mortar composed of one (1) part portland cement and two (2) parts of fine aggregate. The top and face of curb from the top to the ten inches (10") below, or to the top of the street surface, when in place, shall be finished while the concrete is still green by rubbing the surface with a carborundum stone, soft brick, or wood blocks and water until a smooth, even surface is produced.
  - b. Brush finishing or plastering will not be permitted and all rejected curb shall be promptly removed and replaced.
  - c. All joints in the curb shall be promptly cut (opened) from top to bottom and edges adjacent to joints shall be sharp and clean cut.
8. Curing/Protection

- a. The curb shall be cured as specified in PennDOT Publication 408 with either a membrane (paper, burlap, canvas, or similar material) or curing compound.
- b. Curing compound may be applied to retain moisture in concrete to allow complete hydration of the cement.
- c. Plastic, burlap, straw or other types of moisture barrier shall be used to maintain concrete wet during the drying process for at least seven (7) days after the pouring if curing compound is not used.
- d. No concrete shall be placed when the ambient air and surface temperature is below thirty-two degrees Fahrenheit (32°F). To help prevent spalling and deterioration of concrete surface from winter damage, a concrete hardener may be applied twenty-eight (28) days after concrete is poured.

9. Backfilling

- a. After concrete has cured sufficiently, the spaces in front and back of the curb shall be backfilled with approved material in layers of not more than four inches (4") in depth. Each layer shall be thoroughly compacted mechanically to the required elevations. The layers shall be placed by alternating between the front and back of the curb.

10. Paving Restoration

- a. Except for a new land development project, or where a PennDOT Permit is required, asphalt paving disturbed during curb installation or repair shall be restored by the Borough. The property owner shall be responsible for the stone backfill (2A) and compaction in the road.

F. SIDEWALKS

1. Forms

- a. Forms shall be made of wood or metal, straight, free from warp and of sufficient strength when staked to resist the pressure of the concrete without springing. If wood, they shall be nominal two inch (2") planks surfaced on the inside and the top; or if of metal, they shall be of an approved section and have flat surface on top. Forms shall have a depth equal to the depth of the concrete.
- b. All forms shall be thoroughly cleaned and treated with oil, as required to prevent the concrete from adhering to. Other commonly available materials such as motor oil,

bituminous paper or other materials which will adhere to or discolor concrete shall not be used.

- c. Forms that are worn, bent or damaged shall not be used.
- d. The forms shall be accurately set to line and grade in a manner to prevent settlement or displacement.

## 2. Joints

- a. Contraction joints shall be spaced in uniform lengths or sections of five feet (5'), unless otherwise approved by the Inspector.
- b. Contraction joints may be either hand-formed or sawed joints.
- c. Contraction joints shall be three-sixteenth inches ( $3/16''$ ) wide and one-fourth ( $1/4$ ) the slab depth. Sawing of joints shall be done as soon as practical after the concrete has set sufficiently to preclude raveling during the sawing and before any shrinkage cracking occurs in the concrete. The saw cut depth may be decreased at the edge adjacent to a curb or structure to obtain a maximum depth that will avoid damage.
- d. Construction/expansion joints shall be placed no more than every twenty feet (20') with one-half inch ( $1/2''$ ) premolded asphalt impregnated fiber joint material and have tooled edges. The one-half inch ( $1/2''$ ) premolded asphalt impregnated fiber joint material shall be cut to conform to the sectional area and be placed at structures, at the end of a day's work, at the beginning and end of radius, and at a change in horizontal alignment or property line. The one-half inch ( $1/2''$ ) premolded expansion joint filler shall have a removable strip for sealant trough.
- e. Provide joint sealant at construction/expansion joints.
- f. Where existing light standards, poles, fire hydrants and similar structures are within the limits of the sidewalk area, the concrete around such structures shall be scored in a block of twelve inches ( $12''$ ) wider than the maximum dimension of the structure at the sidewalk elevation. Prior to placing the concrete around such structures, premolded expansion joint filler, one-tenth of an inch ( $1/10''$ ) in thickness, shall be placed around the structure for the full depth of the concrete in the sidewalk.

- 3. Handicap Access - New or replacement sidewalks shall be ramped at intersections to facilitate access for the handicapped. Either a single or double access ramp shall be formed in accordance with PennDOT and/or Borough guidelines, as appropriate. All ramps shall comply with the United States Americans with Disabilities Act and all regulations adopted pursuant thereto.

4. Driveways
  - a. New or replacement sidewalks across residential driveways shall be constructed with reinforcing wire fabric to minimize and control cracking.
  - b. Driveways shall be provided with a concrete apron.
  - c. The wire fabric shall be placed with a minimum clearance of two inches (2") from the finished surface of the concrete slab, and continue to the construction joint. A construction joint shall be placed on either side of the driveway. Wire fabric shall be 6 x 6 - W1.4 x W1.4.
  - d. Sidewalks across driveways shall be constructed without any step or break in grade from abutting sidewalk, or at a minimum, shall conform to the United States Americans with Disabilities Act and the regulations adopted pursuant thereto.
5. Placing Concrete - The concrete shall be proportioned, mixed and placed in accordance with applicable requirements of PennDOT Publication 408. The concrete shall be four inches (4") in depth, except at driveways, where the concrete shall have a depth of six inches (6"). The sidewalk shall be reinforced with 6 x 6 - W1.4 x W1.4 wire fabric located in the center of the slab. The concrete shall be struck off, finished and tested in accordance with PennDOT Publication 408. Unless otherwise directed, an edger having a one-fourth inch (1/4") radius shall be used for edging all joints.
6. Curing/Protection
  - a. The sidewalk shall be cured and protected as specified in PennDOT Publication 408 with either a membrane (paper, burlap, canvas or similar material) or curing compound.
  - b. Curing compound may be applied to retain moisture in concrete to allow complete hydration of the cement.
  - c. Plastic, burlap, or other types of moisture bearer shall be used to maintain concrete wetness during the curing process for at least seven (7) days after pouring, if curing compound is not used.
  - d. No concrete shall be placed when the ambient air and surface temperature is thirty-two degrees Fahrenheit (32°F) or lower, unless allowed in writing by the Borough.
  - e. To help prevent spalling and deterioration of concrete surface from winter damage, a concrete hardener may be applied twenty-eight (28) days after concrete is poured.
7. Finishing

- a. Concrete sidewalks shall have broom-finished surfaces perpendicular to direction of pedestrian traffic, as to provide a non-slip surface.
  - b. Sidewalk scoring shall be such to traverse at evenly spaced intervals of not more than five feet (5'). The depth shall be one fifth (1/5<sup>th</sup>) the thickness of concrete and in no case less than one-half inch (1/2").
8. Backfilling - After the concrete has cured sufficiently, the space adjacent to the sidewalk shall be backfilled with approved material in layers of not more than four inches (4") in depth, which shall be thoroughly compacted mechanically to the required elevation and cross section.
9. Brick/Flagstone Sidewalk
  - a. Brick or flagstone sidewalk may be constructed in all zoning districts. A three inch (3") thick concrete slab on four inches (4") of thoroughly compacted stone (2B) must be provided to support the brick or flagstone, in accordance with the Standard Drawings. Brick and flagstone shall be set in a one inch (1") mortar bed. Joints shall be either full mortar joints or a brushed joint using a dry mixture of sand and mortar. All bricks shall be paving bricks.
  - b. As an alternate to the brick or flagstone sidewalk, precast concrete pavers may be used. Pavers shall conform to the ASTM C-936 and the color shall be approved by the Historic Review Board at the time of permit application. The pavers shall be installed on a thoroughly compacted aggregate subbase (2B) and one and one half inch (1 ½") thoroughly compacted sand bed (25-40mm). The aggregate subbase shall have a depth of four inches (4") for normal sidewalk areas, and ten inches (10") where the sidewalk is traversed by a driveway.
  - c. Driveway aprons and curb ramps, which are adjacent to or an extension of brick or flagstone sidewalk, shall be concrete.
  - d. Where the brick or flagstone sidewalk abuts a curb, asphalt impregnated fiber joint material (expansion Joint) shall be provided.
  - e. Replacement of a portion of an existing brick or flagstone sidewalk shall be done using the construction methods and materials contained within these specifications.
  - f. The transition between brick or flagstone sidewalk and concrete sidewalk shall be smooth with no more than one-fourth inch (1/4") grade change.

## PART 5 - INSPECTION/ACCEPTANCE

A. General

1. Acceptance by the Borough shall be in writing and based upon inspection of the completed curb and/or sidewalk.
2. Property owner shall be responsible for all improvements, repairs and/or modifications until the work is accepted by the Borough.
3. Property owner shall be responsible for all corrective work.

B. Inspections

1. Periodic and final inspections will be made by the Borough.
2. Curb and/or sidewalk that has been vertically or horizontally displaced due to subsequent construction phases or negligence shall be either reset or replaced, as directed by the Borough.
3. Cracked, damaged and honeycombed curb and/or sidewalk will not be accepted and the sections shall be corrected to the Borough's satisfaction.
4. Borough reserves the right to require corrections to unacceptable work, using, but not limited to, the following:
  - a. Curb
    1. Removal and replacement
    2. Saw cut crack and seal new joint
    3. Severity and line of crack will determine the corrective action
    4. Minimum length of curb replacement shall be four feet (4')
  - b. Sidewalk
    1. Removal and replacement
    2. Replacement of concrete sidewalk shall be in full panels only
    3. Replacement of sidewalk other than concrete shall be based on an area indicated by the Borough and include full material pieces.

PART 6 - STANDARD DETAILS

The following standard details are part of these Rules, Regulations and Specifications

- |            |                               |
|------------|-------------------------------|
| Detail D1- | Concrete Vertical Curb Detail |
| Detail D2- | Rolled Curb Detail            |
| Detail D3- | Slant Curb Detail             |

- Detail D4- Depressed Curb at Driveway Detail
- Detail D5- Concrete Sidewalk Detail
- Detail D6- Brick/Flagstone Sidewalk Detail
- Detail D7- Concrete paver Sidewalk Detail
- Detail D8- Street Restoration Detail

END

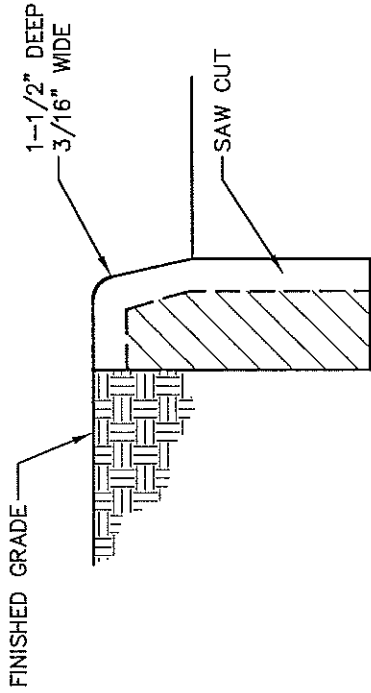

DETAIL 'A' CONTRACTION JOINT

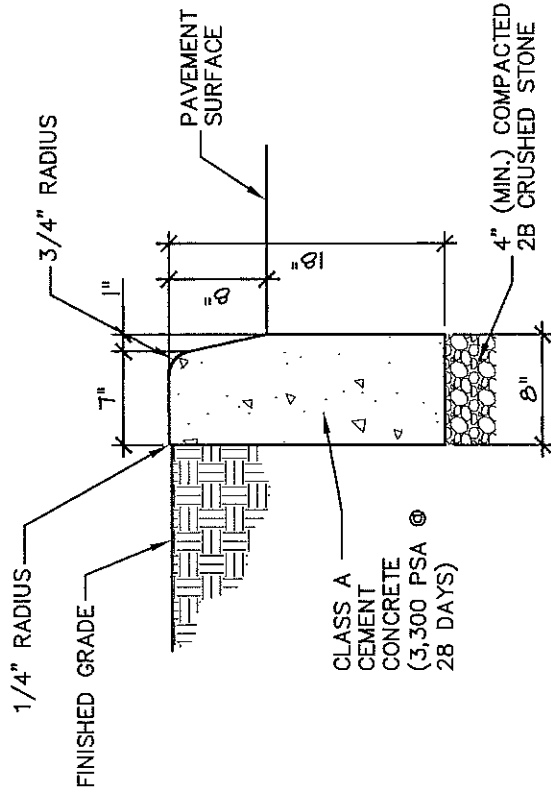

TYPICAL CROSS-SECTION

NOTES:

1. PROVIDE MATERIALS AND CONSTRUCTION MEETING THE REQUIREMENTS OF PENNDOT PUBLICATION 408, SECTION 630 FOR PLAIN CEMENT CONCRETE CURB.
2. SPACE CONTRACTION JOINTS IN UNIFORM LENGTHS OR SECTIONS.
3. PLACE 1/2" THICK PREMOLDED ASPHALT IMPREGNATED FIBER EXPANSION JOINT MATERIAL AT STRUCTURES AND AT THE END OF THE WORK DAY.
4. CUT JOINT MATERIAL TO CONFORM TO CROSS-SECTIONAL AREA OF CURB.
5. PROVIDE 8" MIN REVEAL, UNLESS OTHERWISE APPROVED BY BOROUGH.
6. SEAL PAVEMENT JOINT AT CURB LINE WITH EMULSIFIED ASPHALT (PG 64-22).

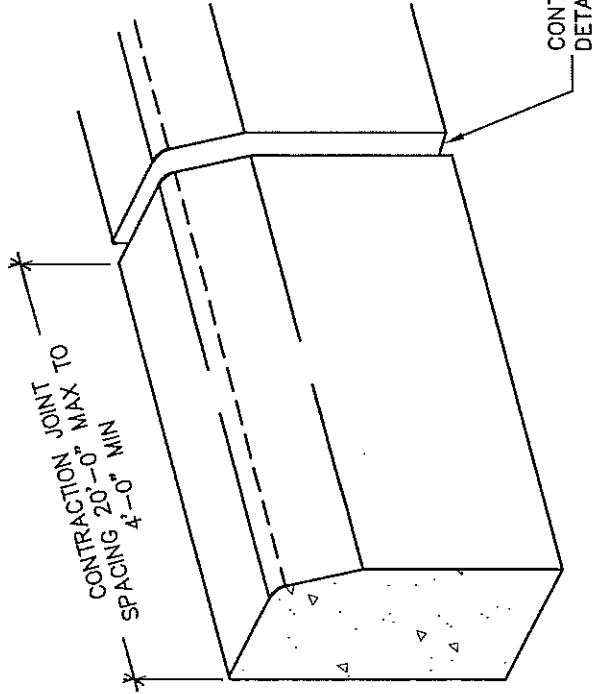

CONCRETE VERTICAL CURB DETAIL

D1 NOT TO SCALE

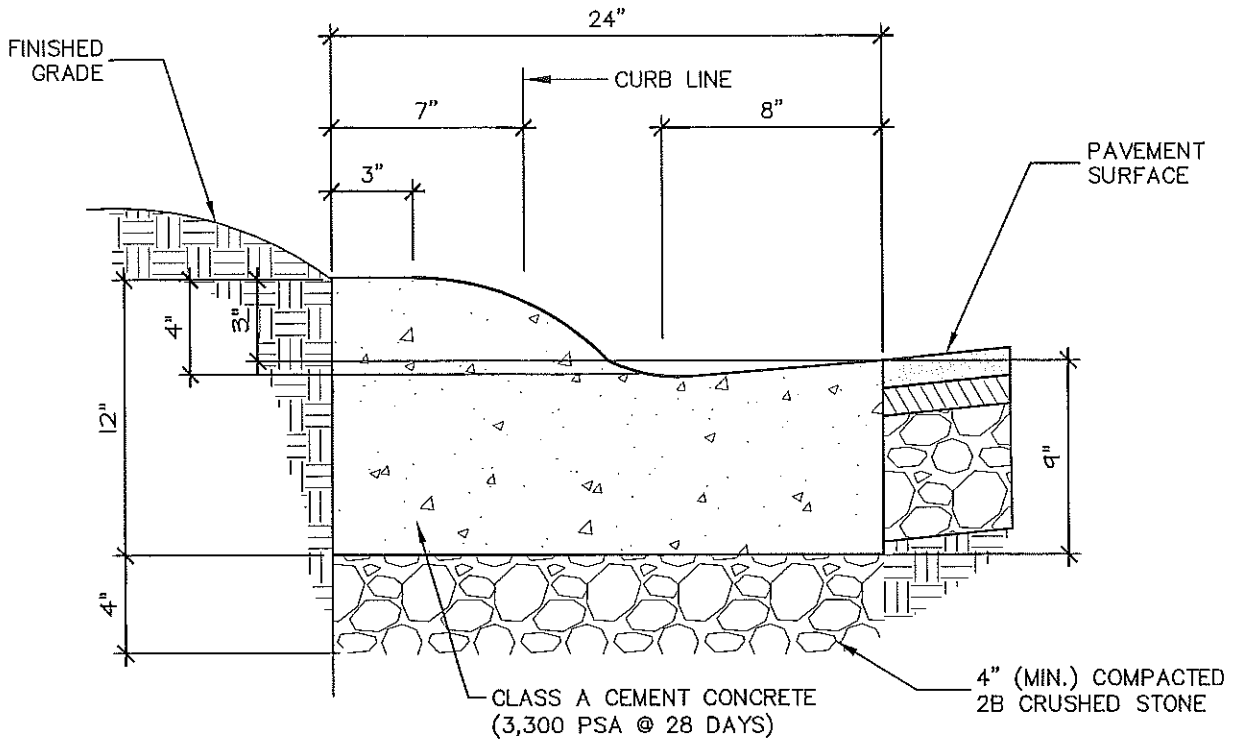

**NOTES:**

1. ROLLED CURB MAY ONLY BE USED UPON OBTAINING WRITTEN APPROVAL FROM BOROUGH.

**D2**

**ROLLED CURB DETAIL**

NOT TO SCALE

**NOTES:**

1. SLANT CURB MAY ONLY BE USED UPON OBTAINING WRITTEN APPROVAL FROM BOROUGH.

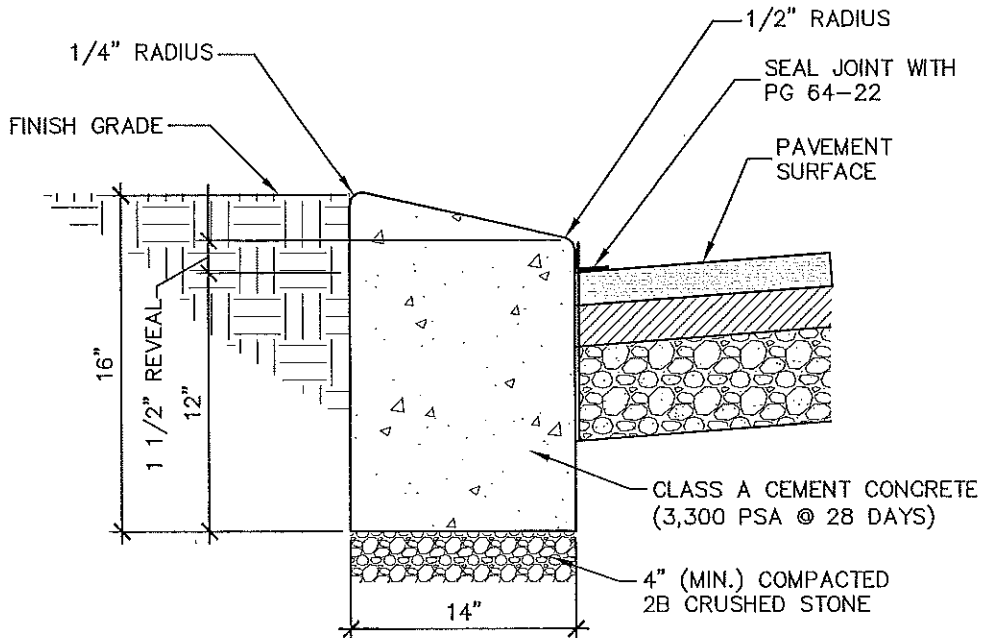

**D3**

**SLANT CURB DETAIL**

NOT TO SCALE

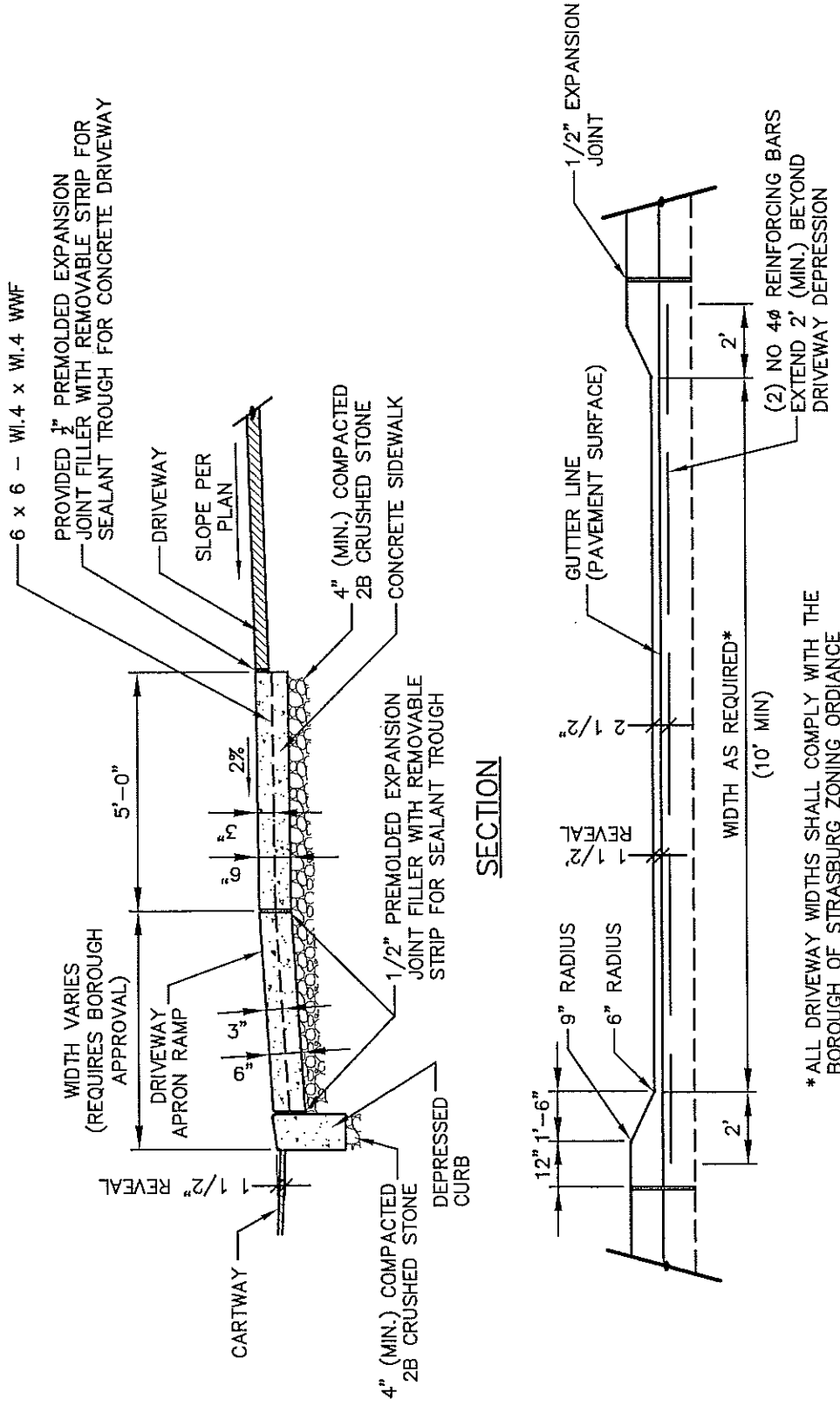

ELEVATION

DEPRESSED CURB AT DRIVEWAY DETAIL

D4

NO SCALE

DRAWING: F:\Data\655 Syracuse Borough\655-004 Curb and Sidewalk Specifications\Ordinances Details.dwg - PLOTTED: Jul 17, 2017 11:14 am

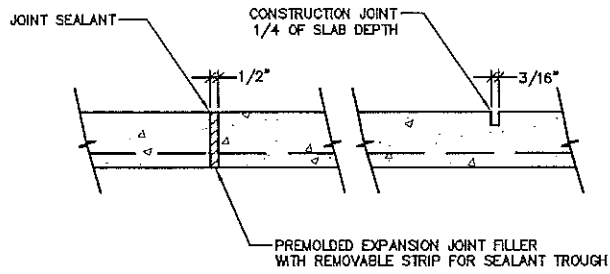

**TYPICAL EXPANSION & CONTRACTION JOINTS**

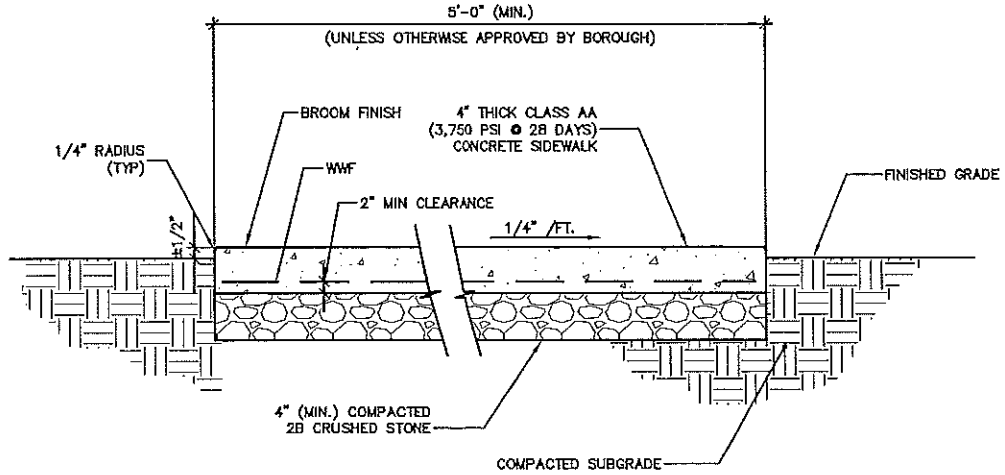

**OPEN/LAWN AREA INSTALLATION**

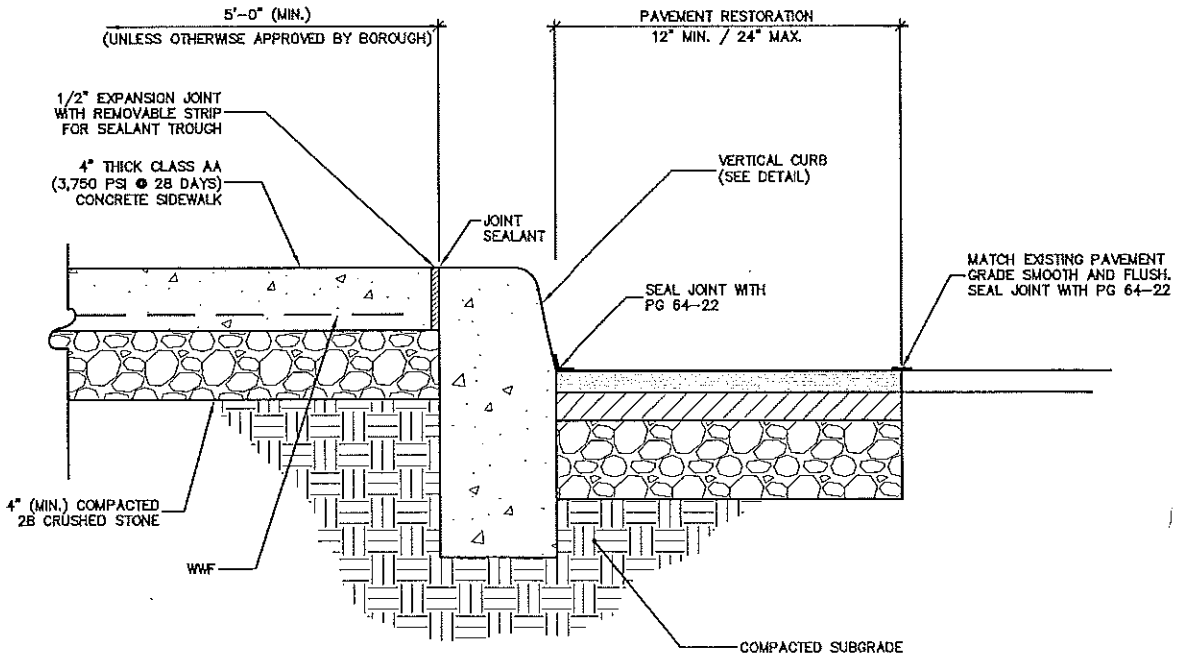

**CURB ADJACENT INSTALLATION**

**D5 CONCRETE SIDEWALK DETAIL**  
NOT TO SCALE

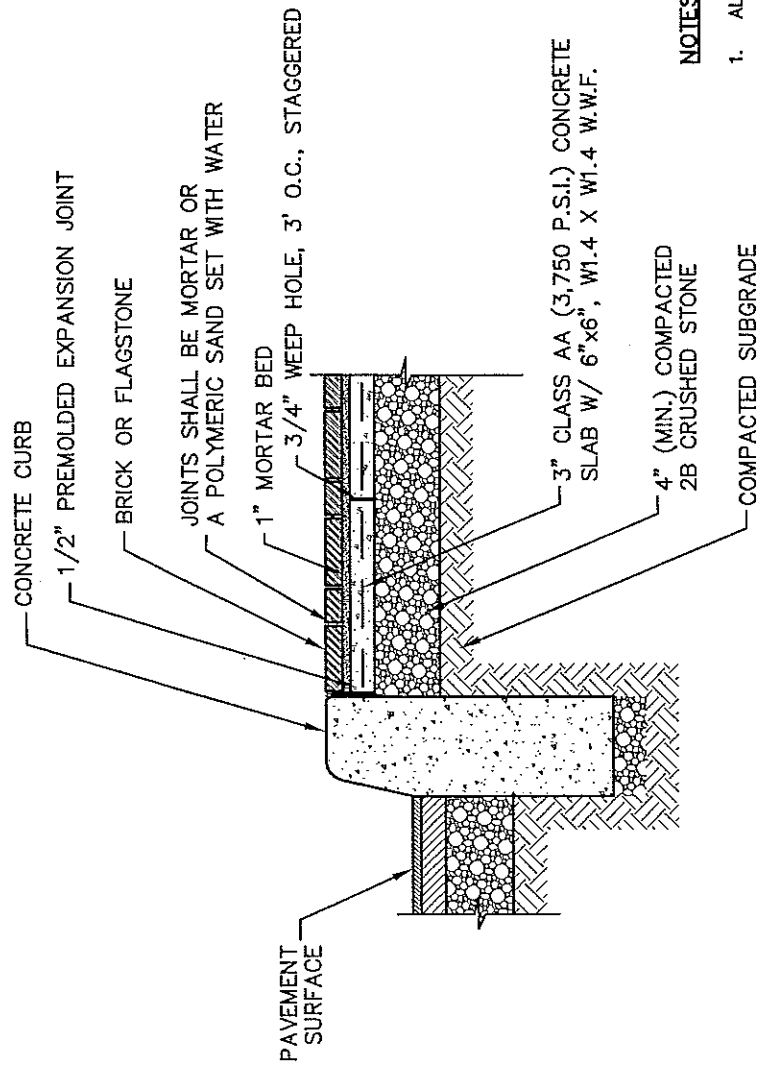

**NOTES:**

1. ALL BRICKS SHALL BE PAVING BRICKS.
2. PROPERTY OWNER WILL NEED TO OBTAIN COLOR APPROVAL FROM BOROUGH OF STRASBURG AND/OR HISTORIC REVIEW BOARD.

**BRICK/FLAGSTONE SIDEWALK DETAIL**

D6

NOT TO SCALE

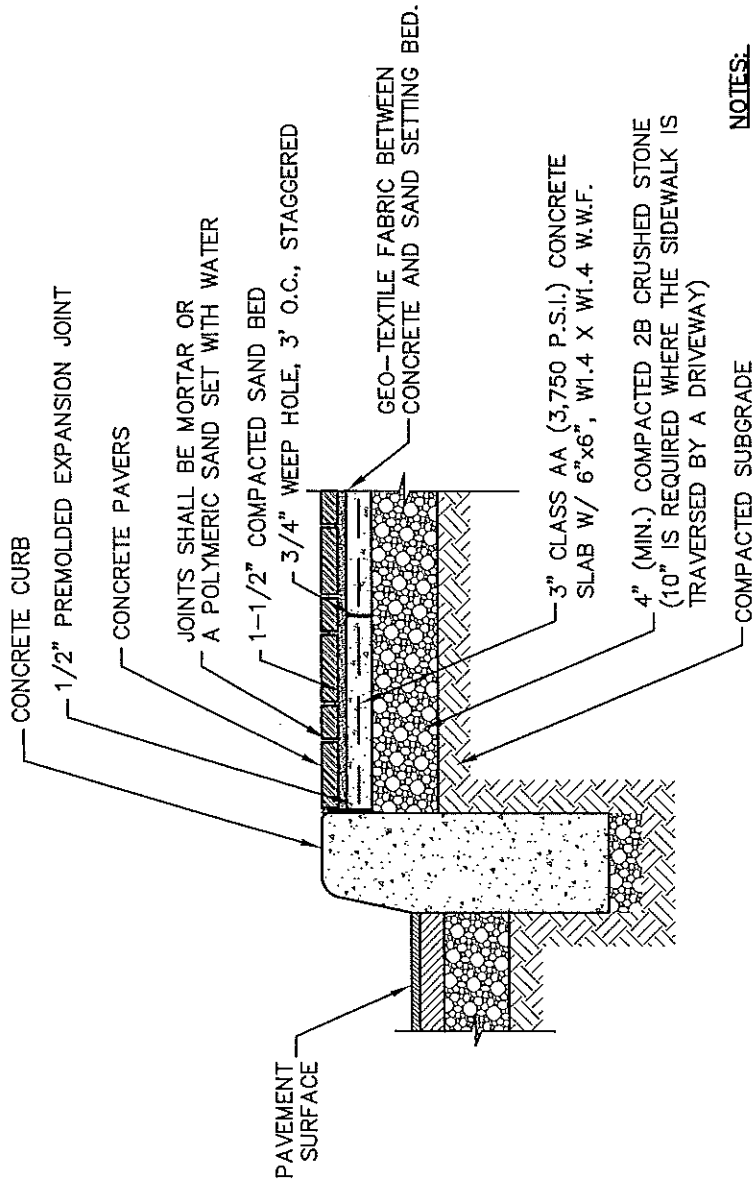

**NOTES:**

1. PAVERS SHALL CONFORM TO ASTM-C936.
2. PROPERTY OWNER WILL NEED TO OBTAIN COLOR APPROVAL FROM BOROUGH OF STRASBURG AND/OR HISTORIC REVIEW BOARD.

# CONCRETE PAVER SIDEWALK DETAIL

NOT TO SCALE

D7

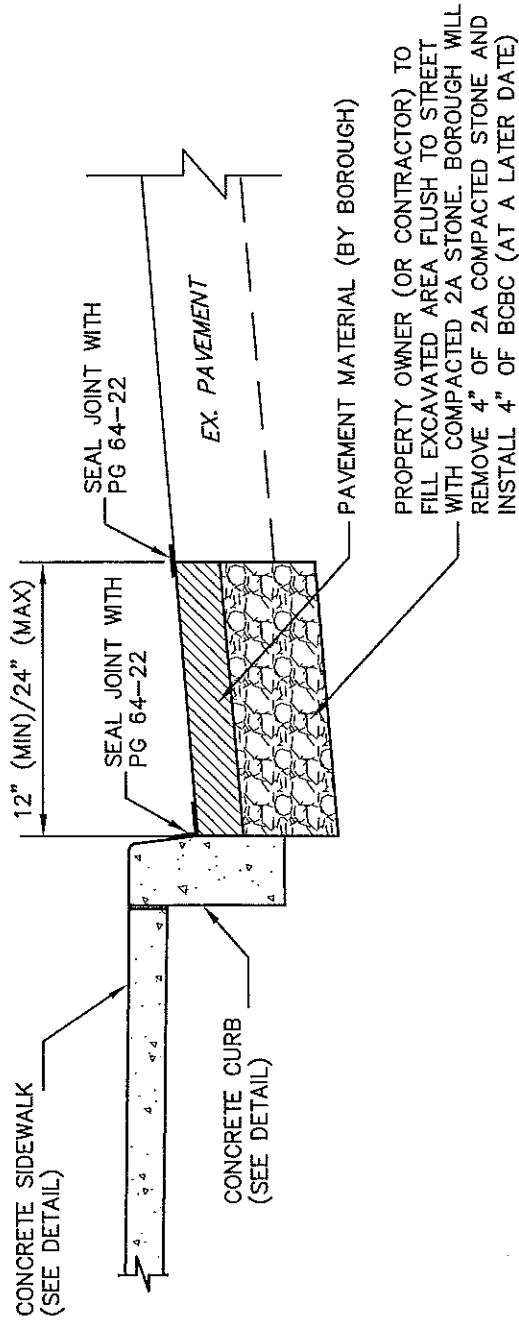

PROPERTY OWNER (OR CONTRACTOR) TO FILL EXCAVATED AREA FLUSH TO STREET WITH COMPACTED 2A STONE. BOROUGH WILL REMOVE 4" OF 2A COMPACTED STONE AND INSTALL 4" OF BCBC (AT A LATER DATE)

## STREET RESTORATION DETAIL

D8

NOT TO SCALE